

GINFORS-Model

MOSUS Workshop, IIASA Laxenburg April 14.-15., 2005

Christian Lutz, Bernd Meyer, Marc Ingo Wolter

Gesellschaft für Wirtschaftliche Strukturforschung mbH (GWS)

Weissenburger Str. 4

D - 49076 Osnabrück

e-mail lutz@gws-os.de)

Tel.: +49 (541) 40933-12

Fax: +49 (541) 40933-11

<http://www.gws-os.de>

Contents

FIGURES	3
TABLES	3
1 THE MODEL GINFORS AND ITS ROLE IN THE MOSUS PROJECT	5
2 A SURVEY OF THE STRUCTURE AND THE DATA BASE	7
3 THE BILATERAL TRADE MODEL	9
3.1 THE DATA SITUATION	9
3.2 THE BASIC STRUCTURE OF THE BILATERAL TRADE MODEL.....	10
3.3 THE MODELLING OF BILATERAL TRADE.....	11
4 THE MACRO MODELS	12
5 THE INPUT-OUTPUT MODELS	14
5.1 THE DATA BASIS	14
5.2 THE MODELING ON THE LEVEL OF SECTORS	16
5.3 THE LINKS BETWEEN THE INPUT-OUTPUT MODELS AND THE OTHER COMPONENT MODELS....	18
6 THE ENERGY EMISSION MODELS (EEM)	19
6.1 ILLUSTRATION OF THE ENERGY BALANCE	20
6.2 THE MODEL	20
7 THE MATERIAL INPUT MODELS (MIM)	22
7.1 DELIMITATION AND OVERVIEW OF THE MODEL STRUCTURE	22
7.2 FORMAL STRUCTURE OF THE MATERIAL MODELS.....	24
8 LITERATURE	28
ANNEX	30

FIGURES

Figure 1: Country Coverage of GINFORS.....	7
Figure 2: The Wheel of GINFORS	8
Figure 3: Schematic Presentation of the Bilateral Trade Model.....	10
Figure 4: Balance of Payments	12
Figure 5: Input-Output Matrix	15
Figure 6: Aggregated Labour Market Sectors	17
Figure 7: Internal and External Links of the Input-Output Model.....	19
Figure 8: Overview Energy Balance	20
Figure 9: Types of MIM models	24

TABLES

Table 1: Countries with Input-Output Tables.....	15
--	----

ABSTRACT

The Global INterindustry FORecasting System (GINFORS) is an economy-energy-environment model with global coverage. A bilateral world trade model links national models for 25 commodity groups and services. All EU-25 countries, all OECD countries and their major trade partners are explicitly modeled. The model is based on time series of international statistics data from 1980 to 2002. Behavioural parameters are derived from econometric estimations assuming bounded rationality of agents with myopic foresight. The model philosophy is comparable to the COMPASS system (Uno 2002), which is focused on the APEC region. Another type of simulation models with global coverage are computable general equilibrium models mainly based on the GTAP data (Hertel 1997). In these models parameters are calibrated to fit a single year data set in compliance to neoclassical theory.

The wheel of GINFORS in figure 2 gives an overview of the system: The bilateral trade model is the heart of the system. For 25 commodities plus services bilateral trade share matrices for 40 countries, the OPEC and the rest of the world are linked. This guarantees consistent linkage of trade volumes and prices. Exports of one country have to be imports of another country. On the global level the trade system is closed. Every spoke of the wheel represents the model structure for a country. The economic part of the country model is a macro model (MM) and an input-output model (IOM). Macro models are included for all countries, whereas IOM are limited due to data availability to 25 countries. The IO models describe the production technology in the countries as reflected in the input structures. Energy-emission models (EEM) are based on energy balances of the International Energy Agency and are available for all countries and regions distinguished in the model. In the EEM total final energy consumption, transformation and total primary energy supply are consistently linked for 12 energy carriers to the economic driving forces that are explained in the economic part of the model. Carbon emissions result from the use of fossil fuels.

Furthermore, material input models have been integrated into the system. For all countries resource use extraction in tons is explained for 6 categories. Their development is either driven by the economic part of the model or the energy model concerning fossil fuel use. Land use models (LUM) are also linked to the economic models. Agriculture as the main source for land use is explicitly modeled in the IOM.

The wheel of GINFORS symbolises the global closeness and identity of the system. Energy use in any part of the world is only possible after extraction of the energy carriers. Imports of one country are exports of another. The whole system is consistently linked and simultaneously solved on a global level.

1 THE MODEL GINFORS AND ITS ROLE IN THE MOSUS PROJECT

Since the Gothenburg summit in June 2001 the concept of sustainable development is in concrete terms a dominant guideline for the policy of the European Union (European Commission 2002). The commission presented an overall strategy which demands to examine the links between economic, social and environmental policies to make them more compatible with sustainable development. Since the European socio-economic development and its use of the environment have impacts far beyond the borders of the community, the sustainable development strategy explicitly stresses the fact that the development of the European Union has to be analysed within a global context.

The MOSUS project (www.mosus.net) is the ambitious attempt to identify possible strategies for a sustainable development in Europe considering the interrelations of

- resource inputs, land use, energy consumption,
- economic development, and
- fundamental social indicators.

From a political point of view the task seems to be huge, and there are many sceptical voices, as to whether the big political bargaining process could ever converge. A necessary but by no means sufficient condition for this is the solution of a big information problem: What does sustainable development mean for the different countries, when it comes to the formulation of *operational* targets for the use of the environment, the economic and social development for the future? What are the *relations* between the targets like? What do we know about the interdependencies between the environment, the economic and the social development in the different countries? How do the different instruments affect nature and the paths of economic and social development? How efficient are these instruments?

Only simulations and forecasts with models which depict the interdependencies between environment, economic and social development can give answers to these questions. Of course, such models have to fulfil certain requirements. There are five requirements, which the simulation model used in the MOSUS project has to fulfil (Meyer, Lutz, Wolter 2003):

1. It has to be a *multicountry* global model. The global coverage is already demanded in the strategy of the Commission. The multicountry approach is needed as policy decisions are made in countries and for countries and not in regions. Of course, all EU 25 and all other countries in the world that are important from an economic and environmental point of view have to be described explicitly.
2. A *multisector* model is needed: The interrelations between the economy and the environment with its complex structures for the different resources and emissions can only be depicted in a sector view on the economy.
3. It follows from 1 and 2 that *international trade* has to be analysed in a *multisector/multicountry* approach. This means that for every product group that is important to describe the economic-environmental interdependencies, the international trade between all important countries has to be depicted bilaterally.

-
4. The model has to give an *endogenous explanation of socio-economic development and its linkage with the environment*. This results from the integrative approach of sustainability that is the basis of the MOSUS project.
 5. The model must be able to describe concrete and realistic policy alternatives. How will the future be in the business-as-usual case? How can this path be influenced by the instruments that are in discussion. A *forecast* model is needed, which is able to reproduce the historical development because of the *statistical significance of its parameters*.

The fundamental qualities - global coverage, endogenous economy and a deep sector and regional disaggregation - are accomplished by the models GTAP (Hertel 1997) and COMPASS (Uno 2002, Meyer/Uno 1999, Meyer/Lutz 2002a, b, c). GTAP distinguishes 57 sectors/commodities and 67 countries and regions, COMPASS distinguishes 36 sectors and 53 countries and regions. The core of both models is a multisector bilateral trade model, and both systems are modeling the interdependencies of economic and environmental (at least with respect to energy consumption) development. More comprehensive modeling in respect to other environmental issues is possible since the fundamental qualities of both models allow for it.

So at first sight, GTAP and COMPASS seem to be similar systems. But there is one big difference: GTAP is a CGE (Computable General Equilibrium) model, whereas COMPASS is a sectorally disaggregated macroeconomic model. West (1995) calls such models “econometric input-output-models”. This means, that GTAP is based on neoclassical theory with the central assumption that all agents are acting with full information in perfect competitive markets, so that all decisions are the result of optimisation based on some assumptions on the technology or the welfare function of the economy.

On the other hand, COMPASS follows evolutionary theory assuming agents to decide under conditions of bounded rationality in non-perfect markets. In this case it is not possible to derive decision rules from optimisation. Many more or less plausible decision rules for one specific activity compete with each other to be integrated in the model, and empirical evidence is needed to select the “right” one (Meyer 2005). So in general, sectorally disaggregated macroeconomic models consist of behavioural parameters estimated by econometric techniques that exist for single equations. To evaluate multi-equation simulation models, historical simulations have proved to be very important evaluation criteria (Pindyck/Rubinfeld 1998, p. 384ff.). The model is tested and equations are adapted until the development of endogenous variables tracks the historical data very closely. Thus, the model is validated empirically.

CGE models take their parameters from the respective literature and calibrate the rest to fit the data of a single year. This means, that these models remain to be theoretical models, since every model structure can be adapted to one data point. On the contrary, parameter choice of econometric models is based on time series data. The set of parameters is tested, as the model must be able to reproduce history for a longer period and not only for one year.

The model COMPASS (Uno 2002, Meyer /Uno 1999) fulfils the five requirements for the economy-energy parts with three shortcomings: The country coverage is not focused on

the EU but on the APEC area. The economic data of the System of National Accounts (SNA) is now published in the SNA 93 classification. New trade data has been published by the OECD, which covers most European countries.

So a new model system has been created based on the philosophy of COMPASS. The new model named GINFORS (**G**lobal **I**Nterindustry **F**ORecasting **S**ystem) uses a different and more up-to-date data set, further developed modelling software and has another country focus. The relations between the economy and the environment are modeled more completely, since not only energy, but also material inputs and land use are integrated. A good impression of the country coverage is provided by Figure 2: The red areas are covered with countries that are explicitly part of the system. The green area shows OPEC (without Indonesia, that is explicitly modeled) and the yellow area represents the rest of the world, ROW. This group consists of economies in Central and South America, in Asia, in Africa and very few in Europe that play a minor role concerning GDP, trade and environmental pressure. The model is open to be extended by further countries.

Figure 1: Country Coverage of GINFORS

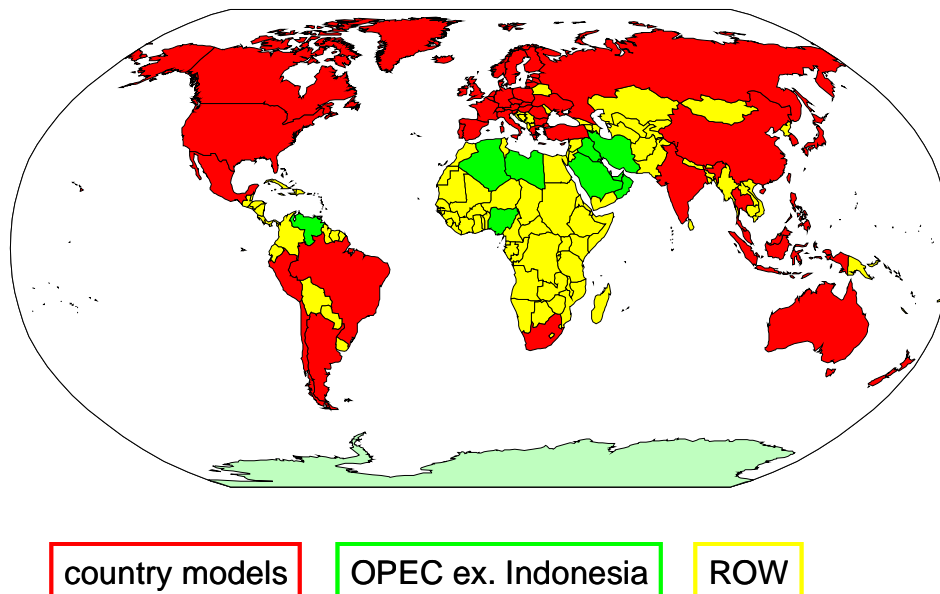

A preliminary version of GINFORS (Meyer/Lutz/Wolter 2004) has been used to make a baseline forecast for the world economy and to estimate the importance of the weakness of German GDP growth for the world economy.

In chapter 2, the paper at hand gives a survey of the model structure and the data base, in chapter 3 the heart of the system, the bilateral trade model, is depicted. A description of the macro-models and the input-output models follow in chapters 4 and 5. The energy-emission-models and the material-input models are discussed in chapters 6 and 7.

2 A SURVEY OF THE STRUCTURE AND THE DATA BASE

The figure below provides a survey of the complete model. Within its centre, there is the trade model. For 25 commodities as well as the service trade, bilateral trade matrices

for the OECD countries and ten further major trade partners are provided. Via this trade context, both quantities and prices are properly allocated to the countries. Each spoke of the wheel stands for the model structure of a certain country. The economic core of a model consists of the macro model (MM) and the input-output model (IOM). Whilst macro models by GINFORS are at hand for all countries, input-output models are available for 25 countries only. The economies of the remaining countries are solely displayed by a macro model. The energy-emission models (EEM) are based on the energy balances of the International Energy Agency (IEA) and are, therefore, available for all countries and regions as well. They picture the energy consumption structured by the relevant energy carriers. The CO₂ emissions are linked with the fossil energy carriers by constant carbon relations.

Figure 2: The Wheel of GINFORS

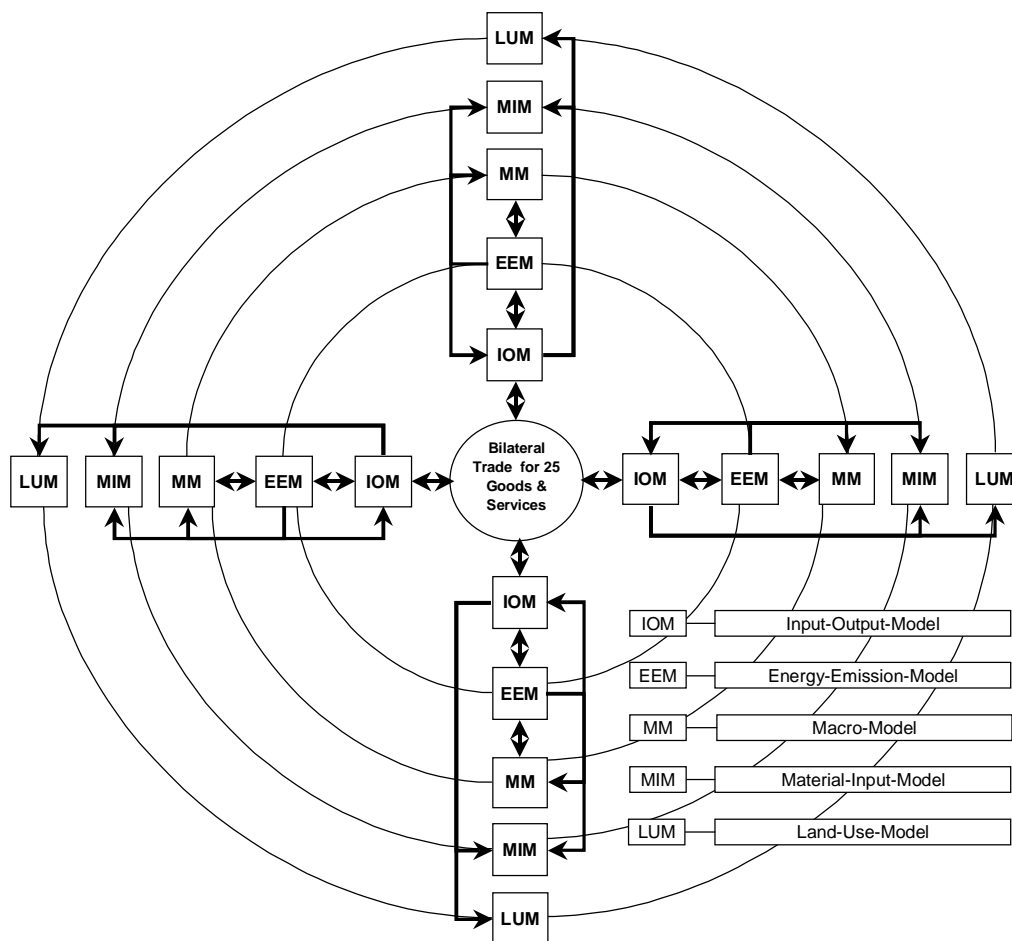

In the course of the MOSUS project (www.mosus.net), material-input models were added to GINFORS. For all the countries displayed in GINFORS, material consumptions structured by six categories are ascertained. Those are linked either with the input-output model, or, for the countries lacking an input-output model, with the macro model. For the projection of those extractions connected with fossil energy carriers, the results of the

energy-emission model are referred to. Moreover, an enhancement by land-use models (LUM) is being worked at.¹

The rings connecting the model segments land use (LUM), material input (MIM), macro model (MM) and energy emission (EEM) signify the global identity of these factors. Referring to the balance of payments, being part of the macro model, this identity can be explained particularly well. Global imports and exports, at least when ascertained in the same price concept, have to be identical. This means the demand for the consistency of the global trade and national models, a demand met by GINFORS.

The data base of GINFORS basically is supplied by five sources: (1) OECD, (2) the International Monetary Fund (IMF), (3) Eurostat, (4) the COMTRADE data banks of the UN and (5) the International Energy Agency (IEA). Furthermore, for a couple of significant countries (e. g. China and Taiwan), national statistics are evaluated. The trade data resulted from a merging of OECD and UN data. The data for the macro model are based on the OECD (2004) „National Accounts of OECD Countries, Detailed Tables“ and the data set „International Financial Statistics“ by the International Monetary Fund (IMF). Since for the model a coherent level of data is necessary (final year 2002), gaps within the data sets were filled by own calculations. In the majority of the cases, the input-output tables were taken from OECD publications and Eurostat. Some of the input-output tables, however, stem from national sources as well. The energy models exclusively refer to the energy balances published by the IEA.

For the land-use models and the material-input models, the data supply by the International Institute for Applied System Analysis (IIASA) and the Sustainable Europe Research Institute (SERI) as part of the MOSUS project form the data base.

3 THE BILATERAL TRADE MODEL

3.1 THE DATA SITUATION

The data for the trade model were taken from two sources, the bilateral trade data base of the OECD and the COMTRADE data base of the UN. For the years from 1989 onward, the OECD supplies imports and exports for every member country structured by 25 composite commodities and 42 countries or regions of origin. The OECD data, however, do not completely display the trade of the non-OECD countries. In order to complete the trade matrices, additional data from the UN COMTRADE data bank and the COMPASS model (Uno 2002) were added. The combination of these data sets results in 25 trade matrices T , displaying all trade flows between exporting countries l and importing countries m for every commodity in US\$ ($TG_{l,m}^k[t]$).

¹ A note on the use of terms: *Model* is the word for those component parts of GINFORS ascertained in particular within the wheel. *Modules* are component parts of a model.

The data base of the service trade model as well refers to the OECD. This set was supplemented by data from the International Monetary Fund (IMF, 2004) on the balance of payments. With these data serving as the basis, a bilateral trade matrix for exporting and importing countries and regions could be ascertained ($TSE_{l,m}^k[t]$).

3.2 THE BASIC STRUCTURE OF THE BILATERAL TRADE MODEL

The Bilateral Trade Model is the core of the GINFORS model. As a bilateral trade model, it links the national models for 25 composite commodities and one service aggregate via the international trade. The display of the bilateral trade by services is, due to their increasing significance, an important enhancement of the approach in comparison to COMPASS. The 42 countries and regions appearing as unaffiliated actors within the trade model, create demand for import in current prices in US\$ and export price indices in US\$ to the trade model and receive demand for export in current prices in US\$ and import price indices in US\$ from the trade model. The service trade model exclusively links the countries via service imports and exports (cf. Figure 3).

This modelling allows both the projection of the global effects of the overall economic development of a country to all the others taking part in trade, and distinguished monitoring of certain commodities. By means of the combination with the IO models of the countries, not only the effects of changes in the demand for export of e. g. finished products may be analyzed directly, but also the resulting trade flows of semi-finished products and primary commodities.

Figure 3: Schematic Presentation of the Bilateral Trade Model

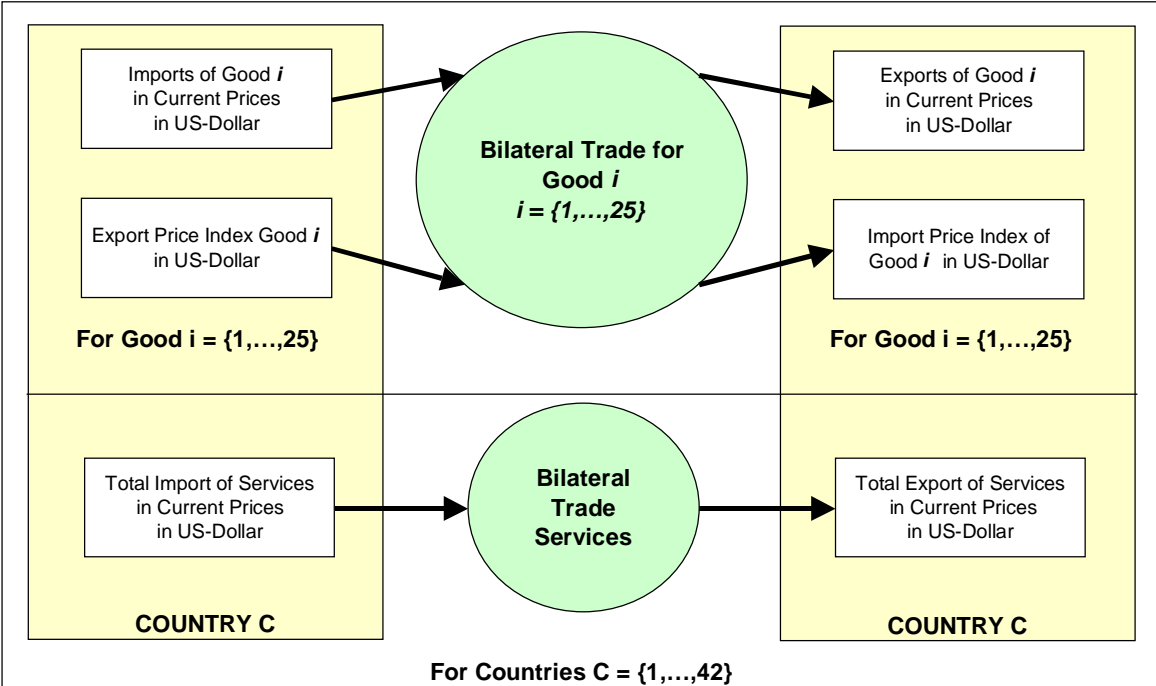

3.3 THE MODELLING OF BILATERAL TRADE

For each composite commodity and service, the bilateral trade model displays the global trade in US\$ completely. The export by country a to another country b equals the import of country b from country a. The imports of a country on the whole are the sum of its imports from all other countries.

Every national model provides import vectors for $k = 25$ composite commodities $m^k_m[t]$ in US\$ and export price vectors $pex^k_l[t]$ for 25 composite commodities as well and the exporting countries l . In turn, every national model receives export vectors $ex^k_m[t]$ and import price vectors $pim^k_m[t]$ for 25 composite commodities. The cube of trade matrices $TG^k_{l,m}[t]$, therefore, has the dimension k commodities, l exporters and m importers, the matrices being square.

By the summation of every commodity k and every importer m of all the exporters l , by means of the sum resulting the share matrix $SG^k_{l,m}[t]$ can be calculated.

$$(1) (SG^k_{l,m}[t] = TG^k_{l,m}[t] / \sum_l TG^k_{l,m}[t] \quad " \quad l, m \{1, \dots, 42\}$$

For every commodity k and every importing country m , $SG^k_{l,m}[t]$ describes the shares of the exporting countries and regions l of the imports of the country m . As a consequence, it can be said:

$$(2) \quad ex^k_l = \sum_m \{ SG^k_{l,m}[t] * im^k_m \}$$

Therefore, the import vectors of every country are apportioned among the exporting nations and consequently summed up by aggregation over all importing countries to the export demands by every country.

By means of a similar process, the demands for service exports are ascertained referring to the demands for service import. There is, however, no differentiation between various services. It can be said:

$$(3) \quad exs_l = \sum_m SSE_{l,m} * ims_m$$

As a further step, the import prices are ascertained. Every country provides an export price $pex^k_l[t]$ for the commodity k . The import price of the country m for the commodity k then is the weighted average of the export prices of its trading partners. It can be said:

$$(4) \quad pim^k_m = SG^k_{1,m} * pex^k_1 + \dots + SG^k_{l,m} * pex^k_l$$

$$pim^k_m = SG^k_{1,m} * pex^k_1 + \dots + SG^k_{l,m} * pex^k_l$$

In matrix terms, this is:

$$(5) \quad pim = (SG)' * pex$$

In general it is assumed that the elasticity of the nominal shares on price changes is 0.5. This means that, with reference to the real market shares, there is a price elasticity of -0.5.

$$(6) \quad [sg^k_{l,m}(t) - sg^k_{l,m}(t-1)] / sg^k_{l,m}(t-1) = \varepsilon * \{ [(pex^k_l(t) - pex^k_l(t-1)) / pex^k_l(t-1)] - [pim^k_m(t) - pim^k_m(t-1)] / pim^k_m(t-1) \}$$

Ceteris paribus, with an increase of export prices by 10% the nominal trade share increases by 5%, whilst the quantity actually traded decreases by 5%. This goes along with

the observation that, besides prices, there are further influential factors affecting the international trade (long-term relationships, quality etc.), an assumption which is based on observations in the last years. Over the years since the end of the observation period (2002), the EURO has been significantly appreciated in comparison to the US\$, resulting in accordingly significant changes in price relations in US\$. Alternative calculations brought forth the fact that the development of the international trade of the EURO countries as well as other currency regions in the years 2003 and 2004 with an elasticity of 0.5 was calculated best.

4 THE MACRO MODELS

The macro models consist of five modules - balance of payments, final demand, monetary market, labour market and the System of National Accounts (SNA).

Balance of Payments

The balance of payments collects the monetary transactions between inlanders and foreigners. In figure 4, on the left the incoming flows, on the right the outgoing ones of the current calculation are recorded. The incoming flows are the commodity exports BPGE, the service exports BPSC, the received income and the received transfers. On the other side, there are the outgoing flows, namely the commodity imports BPGI, the service imports BPSD, the payed income BPID and the payed transfers BPTD. Each of these flows is calculated endogenously within the model. The current account BPCA is the account of the current calculation.

Figure 4: Balance of Payments

BPGE	Goods Exports	BPGI	Goods Imports
BPSC	Service Credit	BPSD	Service Debit
BPIC	Income Credit	BPID	Income Debit
BPTC	Transfers Credit	BPTD	Transfers Debit
BPCA		Current Account	
BPCF		Capital and Financial Account	
BPOB		Overall Balance	

Besides these flows, the balance of payments collects the capital transactions, which in the model are recorded merely with their account BPCF, and the balance of foreign exchange payments, which likewise is referred to merely with its account BPOB. Within the model, the account of the balance of foreign exchange payments is determined exogenously, given that the exchange rate is determined by the policy of the country. In a system of flexible exchange rates, the account of the balance of foreign exchange payments is zero. In any case, with an exogenously determined account of the current calculation the account of capital transactions can be ascertained from the balance of payments as being the rest.

The model consistently links the balances of payments of the single countries. This quality, extremely important for the significance of the applications of the model, is achieved by the consistent collection of the balance of payments for the region „Rest of the World“ within the model. Commodity and service exports and imports can be collected directly from the trade matrices. With the income flows and transfers, it needs to be

considered that, on a global scale, the sum of the incoming flows has to equal the sum of the outgoing ones. Since the region „Rest of the World“ mainly consists of developing countries, it may well be assumed that the drain of income and transfer is zero. As a consequence, the incoming flow of income or transfers of the region „Rest of the World“ has to be the respective difference of the sum of the outgoing and the sum of the received income or transfers of the explicitly monitored countries. The account of the current calculation of the region „Rest of the World“ then results from definition, as is the case with the explicitly monitored countries. Since worldwide the overall balance of foreign exchange payments has to be zero, the account of the balance of foreign exchange payments of the region „Rest of the World“ equals the sum of the accounts of the balances of foreign exchange payments of the explicitly monitored countries with a minus sign. The capital account of the region „Rest of the World“ in turn, as is the case with the explicitly monitored countries, can be calculated by means of the account of the current calculation and the account of the balance of foreign exchange payments. Eventually, it has to equal the accounts of the balance of capital transactions of the explicitly monitored countries with a reversed plus or minus sign.

As within the model the year is the unit period, in the process of currency analyses long-term contexts are of major interest. It is not appropriate for short-term forecasts of the exchange rate relations, which over the past years have been subject to significant changes. The exchange rates of some – not the Euro zone members – countries in relation to the US-Dollar, therefore, were estimated as being dependent on the relation of the GDP deflator of the respective country and the GDP deflator of the USA. The results basically are good with elasticities ranging close to 1. An important implication of this result is the one that mutually all exchange rates in approximation are determined by a price elasticity ranging at 1. Thus, flexible nominal and constant real exchange rates are at hand. There is hardly any other chance for projections of the exchange rates up to the year 2020. This connection is assumed within GINFORS for all countries or currency regions respectively. Differences in the change of prices, as a consequence, result in varying nominal exchange rates. This as well is assumed regarding the relations between the EURO and the US\$ and between the Chinese Yuan and the US\$.

Final Demand

All components of final demand are endogenous variables and mainly explained by income figures. Interest rates play only a minor, sometimes a negligible role. Population, next to GDP, is one important determinant for public consumption. Prices of the different components of final demand are estimated by aggregated prices from the input-output model. If there is no input-output model, aggregated labour unit costs explain aggregated macro prices. Import demand is an aggregate of sectoral imports which are determined in the input-output model. If the country has got no input-output-model, an aggregated import function is estimated with GDP and the relative import price serving as determinants. The vector of import prices in US\$ is given by the trade model. It is transformed into a vector of import prices in local currency by multiplication by the exchange rate. By aggregation, a price for total imports can be calculated.

Monetary Market

On the money markets the discount rate and the monetary base are the instruments of monetary policy. The monetary base is explained in a policy rule function by the development of GDP, the discount rate is determined by the rate of inflation, which also has to be interpreted as a policy rule. Money supply is a function of the monetary base and the discount rate, money demand is dependent on GDP and the government bond yields. A reduced form of money market equilibrium is estimated in which the government bond yield is explained by the discount rate and GDP. For the countries of the EURO area, the interest rates are exogenous, since there are not enough observations for econometric estimations.

Labour market

Labour supply - measured as labour force - is dependent on the development of population, which is exogenous according to the UN (2004) forecast. Labour productivity - defined as the ratio of real GDP and employment - is dependent on the real wage rate and technological trends. Labour demand, i.e. employment, can be calculated by multiplying the inverse of labour productivity by real GDP. The aggregated wage rate is dependent on labour productivity and the development of consumer prices. For countries with input-output models, labour demand and wage determination is described for six sectors, which are consistently linked with the 41 sectors of the input-output model. A detailed discussion of the disaggregated labour demand modeling can be found below in the description of the input-output model. Unemployment is explained by the difference between labour force and employment.

System of National Accounts (SNA)

The SNA modules in short display the macroeconomic accounting of a country. Their prime objective is the ascertaining of available income and financial accounts for the private sector and government. The available income, being a determinant of demand for consumption, is a significant factor, the financial accounts – first and foremost those of the government – are significant target factors of economic policy. Within the centre, there are functions made up to explain taxes and further revenues on the side of the government and the government transfer payments to the private sector, including, of course, redistribution by social security systems.

5 THE INPUT-OUTPUT MODELS

5.1 THE DATA BASIS

The data basis of the input-output models is the so-called input-output tables. Within the lines, they describe in deep disaggregation for 41 economic sectors the deliveries of sectors to other production areas (intermediate inputs) and the deliveries to the final demand, their component parts being final consumption expenditures of private households, final consumption expenditures by government, gross fixed capital formation and export. Within the columns of the table, the costs of the sectors are recorded. First, the intermediate

consumption of the other sectors is collected, followed by the value added, which as well can be interpreted as the costs for the application of the primary inputs labour and capital. The component parts of the value added are production taxes minus subsidies (net taxes on production), depreciation, compensation of employees and profit. By means of the summation of the lines or the columns of a sector, you get as the result its gross output.

Figure 5: Input-Output Matrix

Input-Output-Table in constant prices (basic price concept)				final use							
use of goods	sector input	1.....41		household final consumption expenditure	final consumption expenditure of NPISHs	final consumption expenditures by government	gross fixed capital formation	changes in inventories	valuables	exports	imports
		sector output	AR _{[1][1]}	FD _{[1][1]}							
supply of goods	1	AR _{[43][1]}	AR _{[43][43]}								
Σ intermediate consumption at basic prices		PI _{[1][1]}		FD _{[1][44]}							FD _{[8][44]}
+ net taxes on products				⋮							⋮
= intermediate consumption at purchasers' prices		PI _{[1][1]}		FD _{[1][46]}							FD _{[8][46]}
gross value added											
gross operating surplus											
compensation of employees											
net taxes on production											
industry output		PI _{[8][1]}									

Figure 5 schematically shows an input-output table. Obviously, three quadrants can be distinguished – the intermediate inputs A, the matrix of final demand FD and the matrix of primary inputs PI. Input-output matrices on the whole are available for 25 countries. Table 1 collects those countries along with the base year for which a table in GINFORS is used. The majority of the input-output tables stems from OECD publications. Moreover, for some countries Eurostat tables or national data have been adjusted to the OECD structure.

Table 1: Countries with Input-Output Tables

no.	country (source)	year of compilation	no.	country (source)	year of compilation
1	Australia (OECD)	1994/1995	14	Netherlands (OECD)	1998
2	Belgium (EUROSTAT)	1995	15	Norway (OECD)	1997
3	Canada (OECD)	1997	16	Austria (EUROSTAT)	1995
4	China (OECD)	1997	17	Poland (OECD)	1995
5	Denmark (OECD)	1997	18	Sweden (EUROSTAT)	1995
6	Germany (OECD)	1995	19	Slovak Republic (EUROSTAT)	1998
7	Finland (OECD)	1995	20	Slovenia (EUROSTAT)	2001
8	France (OECD)	1995	21	Spain (OECD)	1995
9	Greece (OECD)	1994	22	Taiwan (National Statistics)	1999
10	Portugal (EUROSTAT)	1999	23	Czech Republic (EUROSTAT)	1999
11	United Kingdom (OECD)	1998	24	Hungary (OECD)	2000
12	Italy (OECD)	1992	25	United States (OECD)	1997
13	Japan (OECD)	1997			

In the spring of 2005, the OECD and Eurostat published further, in part more up-to-date input-output tables. Therefore, in future versions of the model it will be possible to integrate time series of input-output tables for many countries into MOSUS. The implementation of further input-output models, from national sources as well, will be possible. For example, input-output tables by the OECD, Eurostat or national sources are available for Brazil, South Africa, Russia, Korea, Estonia, Lithuania, Romania and Bulgaria.

Furthermore, time series are available for the labour input in employees as well as in currency units within the OECD statistics. These data, however, are not as deeply structured as in the input-output tables, varying between respective countries. Therefore, these factors are displayed by six combined sectors.

The structure of composite commodities is determined for exports and imports by the world trade data. Regarding consumption by private households, the OECD publishes time series structured according to purposes of use. This, on the one hand, is a useful category considering the analysis of consumption patterns, yet on the other hand there is a lack of bridge matrices allowing the transfer of the purposes of consumption by economic sectors. For 11 EU countries, the consumption structures are projected using a model by the WIFO (Kratena/Wüger 2004) and altered in scenarios. For government consumption and capital investments, structures are kept constant or projected in scenarios by exogenous performance targets.

5.2 THE MODELING ON THE LEVEL OF SECTORS

The import prices in domestic currencies $pm_i[t]$, with regard to adaptation lags, result from the import price in US\$ $pmt_i[t]$ and the exchange rate $EXRA[t]$.

$$(7) \quad pm_i[t] = pm_i\{pm_i[t-1], pmt_i[t] * EXRA[t]\}$$

Imports in constant prices $m_i[t]$ (the index of countries is dispensed with in order to safeguard lucidity) depends on the relative price resulting from the import and production price $pm_i[t]/q_i[t]$, measured in local currency, and the final demand $f_i[t]$ for the commodity i :

$$(8) \quad m_i[t] = m_i\{pm_i[t]/q_i[t], f_i[t]\}$$

The vector of the final demand in constant prices $fd_i[t]$ is the sum of the vector of the consumption of private households, the vector of government consumption, the vector of capital investments, respectively calculated via constant structures from the macro variables, and the vector of exports derived from the bilateral trade model. AR is the matrix of those input coefficients defined as the relation between the factor input of the product of the sector i and the output of the economic sector j . The input coefficients are exogenous variables determined on the basis of assumptions concerning technological development. I is the unit matrix, y is the vector of the gross production in constant prices. Therefore, it can be said:

$$(9) \quad y[t] = [I - AR(t)]^{-1} \{fd[t] - m[t]\}$$

By means of the multiplication of the input coefficients of the production factors by their factor prices and the summation of the different types of costs, the result is the unit costs. In vector terms:

$$(10) \quad uc[t] = (AR[t]-MR[t])' * q[t] + MR[t]' * pm[t] + LC[t] * w[t] + t[t]$$

In the process, MR is the input coefficient matrix of imports, $(AR-MR)$ the domestic one. LC is the diagonal matrix of the labour input coefficients, $wj[t]$ being the vector of wages and $tj[t]$ the vector of net commodity taxes per unit.

Production prices $qj(t)$ are determined by the companies via mark-up calculation from the unit costs. Exceptions only occur when, due to the homogeneity of commodities in relation to the global market, the companies are not price leaders, but price takers. This basically is the case on primary commodity markets (mineral oil, natural gas, coal and ores) where, with reference to differences in quality and transport costs, a coherent global market price evolves. Export prices implemented within the bilateral trade model basically are identical to production prices.

$$(11) \quad qj[t] = qj\{ucj[t]\}$$

On the level of sectors, labour demand and the respective wages are ascertained for six combined economic sectors. For this purpose, the necessary explanatory factors from the input-output model are combined by aggregation in order to form these six economic sectors. The six economic sectors shown in figure 6 are consistently linked with the 41 economic sectors of the input-output model.

Figure 6: Aggregated Labour Market Sectors

no.	sectors
1	agriculture, hunting, forestry, fishing
2	manufacturing
3	construction
4	retail&wholesale trade, hotels&restaurants, transport&storage, telecommunication&post
5	finance&insurance, real estate, computer, research&development, other business
6	public administration&defence, health&social work, private households with employed persons, extraterritorial organisation

The wages of the economic sectors, defined as the annual wages per employee, result from a „Shift Share“ regression with the average wage $AWHI[t]$, which again is the result of a Phillips curve with reference to the labour market situation.

$$(12) \quad wj[t] = wj\{AWHI[t]\}$$

The number of employees $e_j[t]$ is dependent on the production y , the real wages w/q and an autonomous trend of technological progress.

$$(13) \quad (13) \quad e_j[t] = e_j\{y_j[t], w_j[t]/q_j[t], t\}$$

The labour input coefficients result from definition as quotients of the employment and the gross production, whilst the sum of wages results from the multiplication of the annual wage per employee by the number of employees.

This modeling implies that a country can only benefit from globalization by reducing the cost of labour or the cost of material. As a consequence, an increase in labour productivity and the efficiency of materials used are major contributions to the improvement of the position on the global market. Both reduce domestic and export prices, thus boosting exports, at the same time lowering imports.

5.3 THE LINKS BETWEEN THE INPUT-OUTPUT MODELS AND THE OTHER COMPONENT MODELS

Figure 7 shows the internal and external connections of the input-output model. At first sight, the large-scale interrelations of the component models of a country and the modules within the input-output model can be perceived. Given that an input-output model is at hand, it is situated in the centre of the modeling of a country. By the bilateral trade model, it is provided with information on import prices and export demand. The macro model provides the base data needed for the ascertaining of the components of the final demand in constant prices. Eventually, the energy-emission model displays energy prices and technological changes.

Assumptions concerning domestic demand and external trade are implemented into the input-output matrix together with the results of the import equations. By means of the Leontief's Inverse, production can be calculated. In combination with the base wage rate and the production prices, it determines the results on the labour market (wages and employees structured by six sectors).

Prices are determined by the so-called „mark up“ hypothesis, according to which companies levy a surcharge on unit costs. Unit costs result from the summation of the component parts of costs – via the import matrix the costs of intermediate input are calculated. The costs of domestic intermediate input result from the combination of production prices and the domestic coefficient matrix. Eventually, labour costs, weighted with the labour input coefficients, are implemented into the calculation. Moreover, commodity taxes are posted at this place.

Production prices as well as export prices basically are determined by the unit costs. Concerning energy prices, the results of the energy module are referred to. In addition, external shocks can be handled, among them there are e. g. changes of global market prices for primary commodities. In this way, changes in the price of iron ore can be displayed.

The dotted lines describe the backflow from the input-output model into the other component models of GINFORS. The results of the import functions and the export prices form part of the Trade Model. The production prices of the energy sectors are consistently integrated into the energy-emission model, causing a change in the demand for energy. The macro model utilizes the aggregated results of the labour market and the price module.

Figure 7: Internal and External Links of the Input-Output Model

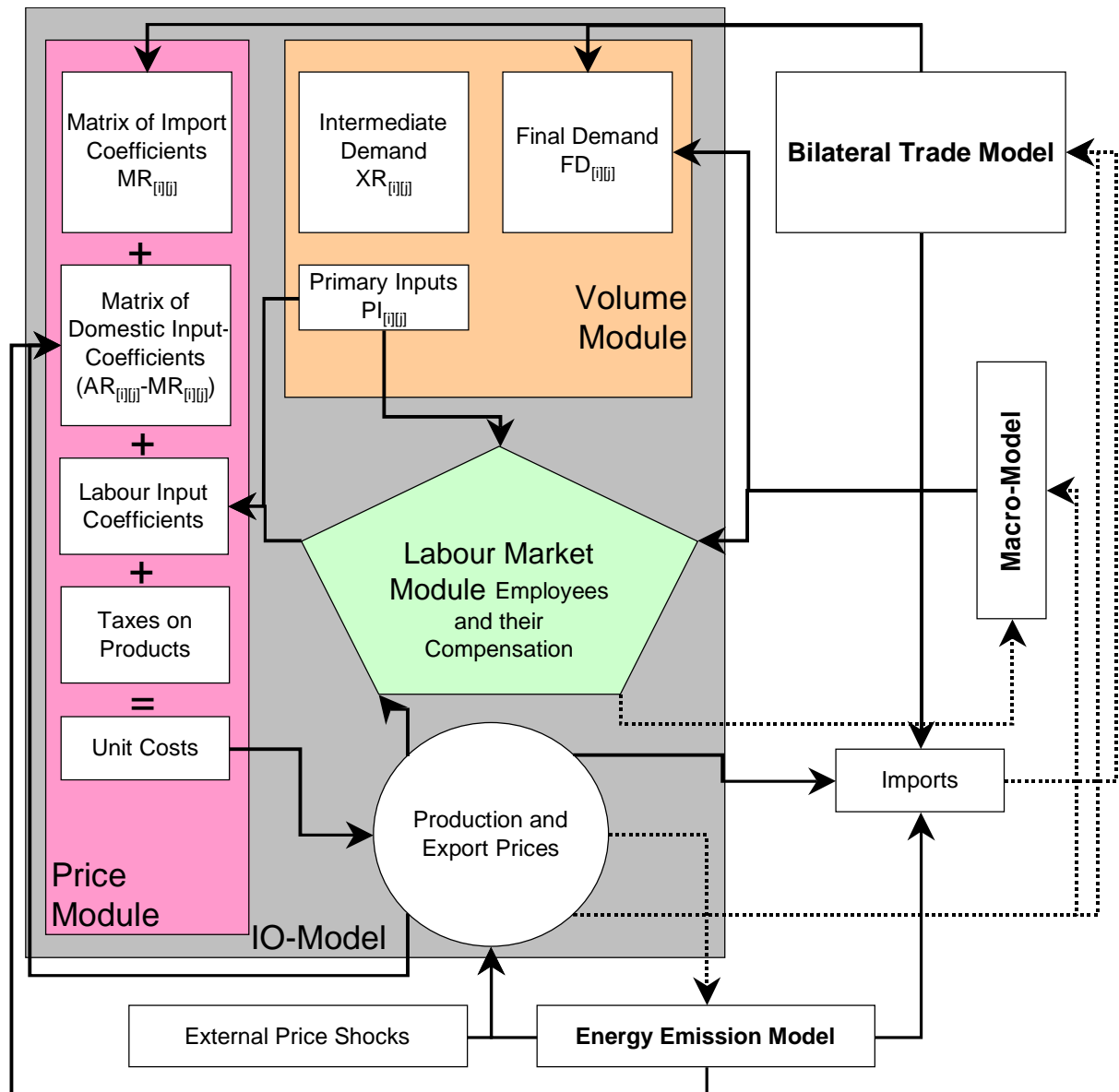

6 THE ENERGY EMISSION MODELS (EEM)

The energy emission models show the interrelations between economic developments, energy consumption and emissions. For this purpose, the variables of the corresponding macro model and of the IO Model – if available – are used as drivers. Vice versa, the expenditure for energy consumption has a direct influence on economic variables. The data basis of the energy models are uniform energy balances in physical units drawn up by the International Energy Agency (IEA 2004 a, b) which have been available for each year from 1960 resp. 1970 on. The CO₂ emissions which are connected with the Total Primary Energy Supply (TPES) via fixed emission factors are also recorded by the IEA (2004 c).

6.1 ILLUSTRATION OF THE ENERGY BALANCE

In the energy balances, twelve energy carriers resp. groups of energy carriers are distinguished in the columns (the complete energy balance is given in the annex). The detailed description of the energy carriers is available in IEA (2004a).

The lines of the energy balances drawn up by the IEA can be subdivided into three parts: final consumption, transformation as well as production and trade. The demand for energy by the companies and households of a national economy is the Total Final Consumption (TFC). Since, in most cases, the consumer himself does not make available the final energy, this is done by the transformation sector. For this purpose, the Total Primary Energy Supply (TPES) is partly transformed into the Total Final Consumption (TFC). The primary energy used can be won in the home country or it can be imported from abroad. Finally, part of the domestic extraction can also be exported abroad.

Figure 8: Overview Energy Balance

		Fossil fuels 1-4	Nuclear 5	Renewable 6-9	Electricity&Heat 10-12	Total 13
Production and trade (1-5)	1 ⋮ 5					
Total Primary Energy Supply (TPES, 6)		Σ 24 + Σ 7-23				
Transformation (7-23)						
Total Final Consumption (TFC, 24)		Σ 26-56				
Total Industry Sector 26-39	26					
Total Transport Sector (41-47)	⋮					
Total Other Sectors (49-52)						
Non-Energy Use (54-56)	56					

Source: IEA(2004a).

6.2 THE MODEL

The Total Final Energy Consumption is calculated according to the following scheme: For the industrial sectors, the total demand for the respective goods and the development of the energy prices in relation to the production price of the sector show the total energy supply. If there is no Input-Output-Model, the development of the industrial sectors is explained by the GDP, instead of the total demand in the sector, together with the price relation of crude oil to the GDP. For the Transport Sector, the Other Sectors – above all Services and Residential – as well as the non-energy use, the demand for energy of the individual traffic sectors resp. of the individual sectors is altogether explained in dependence on the GDP in constant prices and the relative price of the oil price to the GDP deflator. In addition, if several energy carriers make up a considerable share in the energy demand of the sector and are altogether important for the demand of energy, the shares of the individual energy carriers in dependence on the relation of the prices of the energy carriers are estimated for important sectors with a demand for energy. This applies

especially for the areas Services and Residential where mineral oil products, gas and electricity partly compete and substitution processes will result in the long term. In addition, this is checked for a few industrial sectors with a high demand for energy. For all the other cases, the sectoral division of the energy carriers is extrapolated for the future and can be varied in scenarios.

Part of the Total Final Consumption is directly used as Total Primary Energy Supply, another part is won by the transformation of primary energy carriers in secondary energy. This applies, above all, for electricity and heat where important losses in efficiency occur, but mineral oil products, too, are won from crude oil in the refinery process. The transformation is based on the following assumption: For the transformation of coal, crude oil and gas, the relations of the past are extrapolated for the transformation. The production of electricity and heat is summarised in the model. The total use of primary energy carriers depends on the quantities of electricity and heat needed, however, technical trends and the price relation of the most important fossil energy carriers to the production price of electricity may also play a role here.

The Total Primary Energy Supply (TPES) results from the Total Final Consumption (TFC) and the demand for the production of secondary energy. This variable TPES directly determines the CO₂ emissions resulting from the use of energy via the fixed carbon content of the energy carriers (at least as long as there is no technical equipment to make economic use of the CO₂ partition in greater dimensions). The Total Primary Energy Supply can be covered by domestic production or by imports. The import of energy carriers is estimated in dependence of the TPES. Thus it is generally assumed that the import shares approximately remain the same. Furthermore it is possible that energy carriers are exported – this export results from the demand for energy by all the other countries and regions of the model according to the existing trade shares relating to the energy carrier.

For the energy carriers coal and crude oil it is assumed that the international trade prices on the world market develop along the same lines. In contrast to finished goods there are no specific preferences for a country. Price differences between the countries resulting from different qualities and transport costs are not explicitly considered. As regards gas, it cannot be assumed that there is a uniform price development on the world market because of the specific networks. Therefore different prices are listed for Europe, North America and Asia. Within the regions, however, the development of prices is uniform. The world market prices are chosen according to the Energy Outlook of the IEA (2004d): For crude oil, the average crude oil import costs of the member countries of the International Energy Agency in US \$/bbl are taken as pilot price. For coal, the average steam coal import costs of the OECD countries in US \$/ton are fixed as average price. For gas, the natural gas pipeline import prices for the EU member states altogether in national currency/Mbtu, the LNG import prices for Japan and Korea in US \$/MBtu as well as the LNG and Natural Gas Import Prices for the USA as well as Canada and Mexico in US \$/MBtu are shown.

The import prices of the individual countries are calculated by converting the international energy prices into the respective domestic currency:

Coal and Coal Products

$$(14) \quad imlcp_{e,c}[t] = WPCOAL[t] * EXRA_c[t] \quad " \ c \ \hat{I} \ \{1, \dots, 42\}$$

Crude Oil

$$(15) \quad imlcpe_{2,c}[t] = WPOIL[t] * EXRA_c[t] \quad " \ c \ \hat{I} \ \{1, \dots, 42\}$$

Natural Gas

$$(16) \quad imlcpe_{4,c}[t] = WPGASE[t] * EXRA_c[t] \quad " \ c \ \hat{I} \ \{1, \dots, 23, 29, \dots 42\}$$
$$imlcpe_{4,c}[t] = WPGASU[t] * EXRA_c[t] \quad " \ c \ \hat{I} \ \{24, \dots, 26\}$$
$$imlcpe_{4,c}[t] = WPGASJ[t] * EXRA_c[t] \quad " \ c \ \hat{I} \ \{27, 28\}$$

The domestic prices for the energy carriers are estimated in dependence of the import prices. In addition, taxes and further cost variables such as transport and distribution often play a role – these can accordingly be altered in scenarios. In the basic scenario, it is assumed that the tax rates and further costs remain constant in the future.

7 THE MATERIAL INPUT MODELS (MIM)

7.1 DELIMITATION AND OVERVIEW OF THE MODEL STRUCTURE

The domestic extraction world-wide is calculated by means of the Material Input Models. For each country resp. each region of the model GINFORS the material extraction is listed separately according to the categories *used* and *unused extraction*. Furthermore, the extraction is divided into the following material-input categories:

- Biomass
- Hard Coal/ Lignite
- Crude Oil
- Natural Gas (incl. Liquids)
- Metal Ores
- Other Mining and Quarrying

Since the economic models for the individual countries within the model GINFORS are drawn up in such a way that the global economic development can be described by them (global coverage) and since there is a MIM for each country resp. region of GINFORS, these MIM's do also comply with the feature „global coverage“.

According to the handbook for the drawing up of Material Flow Accounts (European Commission, 2001) the material input of a country is divided into domestic and imported material flows. Furthermore, the *unused* domestic extraction is shown besides the domestic extraction used. In addition to the imported material flows, the indirect flows associated with imports are listed. From the domestic extraction used and the direct flows imported, the Direct Material Input (DMI) can be calculated for each country. Together with the two other data recorded, the Total Material Requirement (TMR) of a country is produced.

DMI and TMR cannot be directly calculated from the data of the MIM's in GINFORS since only the used and unused domestic extraction is recorded for each country. However, it cannot be concluded from this fact that the global extraction is insufficiently shown in

GINFORS. On the contrary, an aggregation of all TMR's of the countries in GINFORS would lead to a doubled recording of some material flow since the extraction allocated to the imports has already been recorded as domestic extraction of another country. If the aim is to calculate the material extraction world-wide, the delimitation of the extraction recorded in the MIM's is appropriate and necessary.

Furthermore GINFORS shows by means of its global trade flows the effects of variations in the import demand of a country on the extraction world-wide, i. e. for every imported good recorded in GINFORS (cf. description world trade, 25 groups of goods) the corresponding material extraction in the world can be calculated. If, for example, for Germany the import demand in constant prices for automobiles is increased by one billion € in comparison with a basic simulation, this change in the demand for imports can be brought in relation to all global changes regarding extraction. Thus the direct and indirect imported material flows can be calculated for this import good.

The analysis of the material flows in GINFORS, however, goes beyond this as its drawing up also complies with a global consistency. Furthermore the countries of origin of the imported material flows can be identified, and the primary and secondary effects can be distinguished. The primary effect means that the exports of a country rises because of the increased demand for imports e. g. for cars by Germany and the production of cars in the exporting country grows accordingly. Thus there is a potential increase in extraction in the exporting country.

The secondary effect has two components: On the one hand, the increased demand for automobiles leads, in turn, to a growing demand for metals in the exporting country which results in extraction in a third country. This supply chain finally leads to an increased extraction in a country producing iron ore. Secondly, every variation in the demand leads to economic adaptations. A growing demand for imports in one country does not only lead to an increase of exports to the same extent but also causes a growth in production, higher work inputs and increasing wages. An increase in consumption or investments may result accordingly. The change in the economic demand then also involves changes in the extraction.

In a conventional material input balance the material input is calculated on the basis of the quantities imported by means of proportionality factors. Here it is indispensable to operate with global factors with regard to both the countries of origin and the materials. At the same time it is difficult to evaluate the material flows involved in the imports of finished products owing to the complexity of the underlying production process and the preceding supply chains.

The MIM's are so-called „subordinate“ models, i. e. the MIM's take up the results of the energy models and of the economic models and convert them but do not give back any information to the modules mentioned before. Basically two types of material models can be distinguished. The basic types are determined by the origin of the economic factors. These can either come from an Input-Output-Model (IOM) or from a Macro-Model (MM). Especially the categories *biomass* and *other mining and quarrying* are determined in that way. The material models which are based on a macro model can furthermore be distinguished by the respective consideration of the foreign trade. There is a model

showing this diversification, however, it has been ignored in the following graphic representation serving as a survey in order to guarantee its clearness.

Figure 9 shows the procedure: While for the basic type 1 the development of the extraction category *biomass* is determined by the production development from the Input Output Model, the same categories are driven by the development of e. g. the gross domestic product in constant prices in the type 2. The remaining extraction categories are independent of the type chosen. The extraction of *metal ores* is explained by the global demand for metal. The extractions of fossil fuels (*coal, oil, gas*) are coupled with the energy models.

Figure 9: Types of MIM models

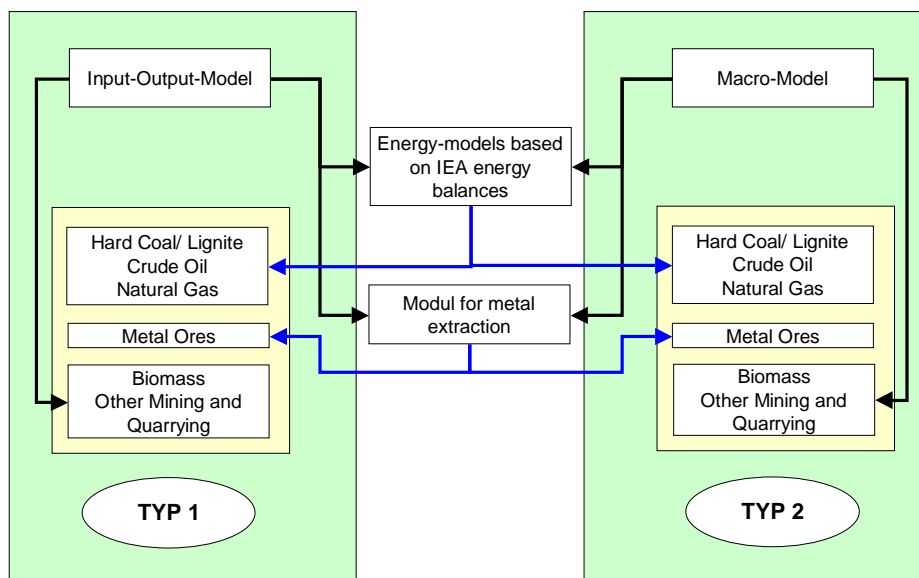

7.2 FORMAL STRUCTURE OF THE MATERIAL MODELS

The material models are depicted by means of four matrixes. In each matrix the countries c (1 to 55) are listed in the columns for each year. In the lines m of each matrix the six categories of material extraction are listed. Only the results matrix covering the total extraction additionally contains the lines of the *unused domestic extraction* and the sum of the *used* and *unused domestic extraction* as well as three total sums. This matrix *MATERIALR* accordingly consists of 21 lines.

The starting point of the material models are the developments of economic and energetic factors serving as “drivers” of the material input. These factors are shown in the matrix $MATERIALD_{m,c}[t]$. As mentioned before, the extraction of fossil materials is determined by the development of the energy model of the respective country. The extraction of metal ores depends on the development of the world market. *Biomass* and *Other mining and Quarrying* are directly derived from economic factors. In the following the individual economic and energetic factors resp. indicators are described before the connection between the results matrix *MATERIALR* and the Driver Matrix will be illustrated.

Material Input of Fossil Fuels

The energy balance of a country (cf. Annex I) shows the demand for energy, the transformation of energy and the energy supply. Part of the energy supply is covered by the domestic production (line 1 of the energy balance). The variables in the energy balance are given in the unit “million tons oil equivalents” and thus are units of quantities like the material flows. The domestic production of coal (column 1), crude oil (column 2) and gas (column 4) are inserted into the matrix *MATERIALD* as indicator for the development of the material flows. The index *c* stands for the 42 countries and regions of the model GINFORS which have their own lines and columns in the trade model. *EB* is the energy balance of the country *c*:

$$(17) \quad \textit{Coal and Coal Products} \\ \textit{MATERIALD}_{2,c}[t] = \textit{EB}_{1,1,c}[t] \quad " \ c \ \hat{I} \ \{1, \dots, 42\}$$

$$(18) \quad \textit{Crude Oil} \\ \textit{MATERIALD}_{3,c}[t] = \textit{EB}_{1,2,c}[t] \quad " \ c \ \hat{I} \ \{1, \dots, 42\}$$

$$(19) \quad \textit{Natural Gas} \\ \textit{MATERIALD}_{4,c}[t] = \textit{EB}_{1,4,c}[t] \quad " \ c \ \hat{I} \ \{1, \dots, 42\}$$

For those countries that are not direct partners in the global trade the gross domestic product in the prices of 1995 is used as driver for all the three variables.

Metal Ores

In order to be able to determine the global demand for metal ores, the demand for wrought metals (*pig iron, crude steel, aluminium, refined copper and lead, nickel, zinc and tin*) is determined firstly. For this purpose, the produced quantities of these metals and alloys are extrapolated by means of the economic indicators of the respective countries. The data for the 8 metal vectors are derived from the Statistic Annual For Foreign Countries by the Federal Statistic Office of Germany (2004) and are based on the analysis of different international statistics by the German Federal Agency. The output data of the sectors *iron and steel* (12) as well as *non-ferrous metals* (13) are used as indicators for the production of the different metals. For those countries where there is no specific model for the individual sectors, the gross domestic product in constant prices is used as indicator. It has, however, to be stated that by far the largest output of metals is produced by the big industrial nations. As a rule, there is an IO Model for these countries so that the total output can be shown appropriately.

The total output of metals in one year is now calculated from the individual vectors for the metals separated according to the producer countries by the aggregation over all producing countries and metals. On the assumption that the shares of the individual countries in the extraction of ore do not change and the structure of the year 2002 can be used, the extraction of metals in the countries *c* is driven by the aggregate of the material output *METAL[t]*. For each country this variable is accordingly inserted as driver in the matrix *MATERIALD*:

$$(20) \quad \textit{Metal Ores} \\ \textit{MATERIALD}_{5,c}[t] = \textit{METAL}[t] \quad " \ c \ \hat{I} \ \{1, \dots, 54\}$$

Other Mining and Quarrying

The extraction of stones and ground is above all classed with the group *other mining and quarrying*. The extraction from quarries, gravel-pits and the like belong to this group. The usual recording of the data for erosion and excavation in the *unused extractions* with building projects is not done here owing to the extraordinarily poor data available in this field. Thus the material input *other mining and quarrying* generally are initial products of the building industry as well as direct results from the construction of new buildings. Considering these facts it is assumed that the development of this material-input category exclusively depends on domestic factors. For this reason, the gross domestic product in constant prices $GDPTR_c[t]$ is considered as indicator for the development of this material input. It has to be taken into account that this material flow leads to the most considerable extraction. The share in the total extraction world-wide is approximately 25%.

$$(21) \quad \textit{Other Mining and Quarrying} \\ \textit{MATERIALD}_{6,c}[t] = \textit{GDPTR}_c[t] \quad " \quad c \hat{I} \{1, \dots, 54\}$$

Biomass

The material input *biomass* is of similar importance as *other mining and quarrying*. More than 20% of the total extraction belongs to this material flow. In contrast to *other mining and quarrying* this material flow is a factor strongly influenced by the international trade since the place of production and the place of consumption are usually not the same (cf. coffee, tea, cereals etc.). For this category *biomass* it is therefore necessary to proceed in a detailed manner. Three types of drivers are distinguished here: (1) If there is a Input Output Model for a country, the material flow of this country is extrapolated by the output of the sector agriculture $iotlr_1[t]$. In such a model the demand for the export of agricultural products has explicitly been considered owing to the model correlation so that the output represents both the domestic demand and the demand resulting from the exports.

$$(22) \quad \textit{Biomass Type (1)} \\ \textit{MATERIALD}_{6,c}[t] = \textit{iotlr}_{i,c}[t] \quad " \quad c \hat{I} \{\textit{IO-Countries}\}$$

Type (2) are countries that cannot be represented by an I-O-Model because of lacking data but which nonetheless have a disaggregated export vector for 25 goods. For this reason, a two-step procedure is used here. The production of biomass is assigned to two causes: export and domestic use. The material flow is divided according to the export quota. Those part of the biomass resulting from the export is accordingly extrapolated along with the development of the export demand in constant prices for the groups of goods *agriculture, hunting, forestry and fishing*. The domestic use of this type (2) is determined by the development of the gross domestic product in constant prices $GDPTR_c[t]$. Thus it is guaranteed that both the correlation of the foreign trade and the domestic demand are considered appropriately. The intermediate step via the matrix *MATERIALD* is not taken, but the material input which is given in the matrix *MATERIALR* is calculated directly. For this purpose, the exports in constant prices $exr_{1,c}[t]$ and the $GDPTR_c[t]$ each are evaluated by the corresponding factor (*bioexpf* ~ factor for the exports; *biodomf* ~ factor for the domestic use) mirroring the proportionate composition and considering the proportions in comparison with the material flow.

$$(23) \quad \text{Biomass Type (2)}$$

$$\text{exported biomass} = \text{bioexpf}_c * (\text{exusc}[1]/\text{exusp}_c[1])$$

$$\text{domestic used biomass} = \text{biodomf}_c * \text{GDPTR}_c[t]$$

$$\text{MATERIALR}_{6,c}[t] = \text{exported} + \text{domestic used biomass}$$

" $c \hat{I} \{ \text{Countries with detailed trade} \}$

Type (3) is characterised by the fact that there is no detailed recording of the foreign trade. In such cases the extrapolation is therefore done by means of the gross domestic product in constant prices *GDPTR*.

$$(24) \quad \text{Biomass Type (3)}$$

$$\text{MATERIALD}_{6,c}[t] = \text{GDPTR}_c[t] \quad " \quad c \hat{I} \{ \text{Countries with aggregated trade} \}$$

Now that the individual decisive factors of the material models have been explained the extrapolation of the material input is described in the following. On the basis of the matrix with the data *MATERIALD* a coefficient matrix *MATERIALC* is calculated for the final year of the set of data. For this purpose, the original matrix *MATERIALR* is divided by the matrix with the indicators:

$$(25) \quad \text{MATERIALC}_{m,c}[t=2002] =$$

$$\text{MATERIALD}_{m,c}[t=2002]/\text{MATERIALR}_{m,c}[t=2002]$$

" $m \hat{I} \{ 1, \dots, 6 \}$ und $c \hat{I} \{ 1, \dots, 54 \}$

In a simple model the material flows could be extrapolated with this approach. However, with constant coefficients it would be assumed that the extraction remains unchanged in comparison with the indicators and there would be no partial uncoupling of the material input from the economic development any more, as could be observed in the past. For this reason an „efficiency“-matrix *MATERIALE* is introduced which records the development of the uncoupling. Starting from the year 2002 where the matrix is equal to one in all positions, the figures assumed for the future development of the uncoupling are separated according to the material-input categories and countries. These figures can be interpreted as “shrinking factors” indicating the percentage by which the uncoupling progresses yearly. For the years following 2002 the material model shows the following:

$$(26) \quad \text{MATERIALR} = \text{MATERIALE} * \text{MATERIALC} * \text{MATERIALD}$$

" $m \hat{I} \{ 1, \dots, 6 \}$ und $c \hat{I} \{ 1, \dots, 54 \}$

The lines 1 to 6 of the material results matrix *MATERIALR* list the used extraction. As to the unused extraction (lines 8 – 13) it is assumed that this is in a direct proportionate relation to the used one. It is expected that if e. g. metal ores are extracted there is always a certain quantity of unusable ore stones. This may, however, be an understatement since with the increasing exploitation of easily accessible deposits more and more deposits have to be used where the access is more complicated so that an over-proportionate development regarding the unused material inputs could be assumed. At the same time, an under-proportionate development can be assumed if the technical development leads to more efficient methods of mining. In the model it is given:

$$(27) \quad \text{MATERIALR}_{8-13,c}[t] = \text{MATERIALR}_{8-13,c}[t-1]$$

$$* \text{MATERIALR}_{1-6,c}[t]/\text{MATERIALR}_{1-6,c}[t-1]$$

The aggregates can be calculated subsequently and the result is a complete *MATERIALR* matrix with 21 lines.

8 LITERATURE

Commission of the European Communities/IMF/OECD/UN/Worldbank (1993): System of National Accounts. Brussels, Luxembourg, New York, Paris, Washington, D.C.

European Commission (2002): A European Union Strategy for Sustainable Development. Luxembourg: Office for Official Publications of the European Communities.

Federal Statistic Office of Germany (2004): International Statistical Yearbook 2004, Wiesbaden, pp. 267-276.

Hertel, T. W. (1997): Global Trade Analysis. Modeling and Applications. Cambridge University Press.

IEA (2004a): IEA Statistics Energy Balances of OECD Countries 2001-2002, Paris.

IEA (2004b): IEA Statistics. Energy Prices & Taxes, Quarterly Statistics, Second Quarter, Paris.

IEA (2004c): IEA Statistics. CO₂ Emissions From Fuel Combustion 1971-2002, Paris.

IEA (2004d): World Energy Outlook, Paris.

International Monetary Fund (2004): International Financial Statistics Yearbook, Washington, D.C..

Kratena, Kurt/Wüger, Michael (2004): A consumer demand model with “Energy Flows”, Stocks and “Energy Services”. WIFO working paper 237/2004.

Meyer, B./Uno, K. (1999): COMPASS – Ein globales Energie-Wirtschaftsmodell, in: ifo-Studien, **45**, pp. 703-719.

Meyer, B./Lutz, C. (2002a): IO, macro-finance, and trade model specification. In: Uno, K. (ed.): Economy-Energy-Environment Simulation: Beyond the Kyoto Protocol. Dordrecht, Boston, London, pp. 55-68.

Meyer, B./Lutz, C. (2002b): Endogenized trade shares in a global model. In: Uno, K. (ed.): Economy-Energy-Environment Simulation: Beyond the Kyoto Protocol. Dordrecht, Boston, London, pp. 69-80.

Meyer, B. /Lutz, C. (2002c): Carbon tax and labour compensation - a simulation for G7. In: Uno, K. (ed.): Economy-Energy-Environment Simulation: Beyond the Kyoto Protocol. Dordrecht, Boston, London, pp. 185-190

Meyer, B./Lutz, C./Wolter, M. I. (2003): Global Multisector/Multicountry 3 E Modelling: From COMPASS to GINFORS. Paper presented at the 2003 Berlin Conference on the Human Dimensions of Global Environmental Change. Berlin, December, 5.-6., 2003.

-
- Meyer, B./Lutz, C./Wolter, I. (2004): Economic Growth of the EU and Asia. A First Forecast with the Global Econometric Model GINFORS. Policy and Governance Paper Series No. 26. Keio University, Tokyo. <http://coe21-policy.sfc.keio.ac.jp/en/wp/index.html>
- Meyer, B. (2005): Strukturanalyse. In: Herrmann-Pillath, C./Lehmann-Waffenschmidt, M. (Hrsg.): Handbuch Evolutorische Ökonomik. Berlin.
- National Bureau of Statistics of China (2004): China Statistical Yearbook, China Statistic Press, China.
- OECD (2004): National Accounts of OECD Countries, Detailed Tables, Volume IIa and IIb, 1991-2002, Paris.
- Pindyck/Rubinfeld (1998): Econometric Models and Economic Forecasts. 4. vol., Boston.
- United Nations (2005): World Population Prospects: The 2004 Revision. <http://esa.un.org/unpp/>.
- Uno, K. (2002): Economy-Energy-Environment Simulation: Beyond the Kyoto Protocol. Kluwer Academic Publishers. Dordrecht, Boston, London.
- West, G (1995): Comparison of Input-Output, Input-Output and Econometric and Computable General Equilibrium Models at the Regional Level, Economic Systems Research **7**, pp. 209-227.

ANNEX

IEA Energy-Balance

ENERGY BALANCE	Coal and coal products	Crude oil	Petroleum products	Natural Gas	Nuclear	Hydro	Geothermal	Solar/Wind/other	Combustible Renewables and Waste	Heat production from non-specified comb. fuels	Electricity	Heat	Total
1 Production													
2 Imports													
3 Exports													
4 International Marine Bunkers													
5 Stock Changes													
6 TPES: Total Primary Energy Supply													
7 Transfers													
8 Statistical Differences													
9 Public Electricity Plants													
10 Autoproducer Electricity Plants													
11 Public CHP Plants													
12 Autoproducer CHP Plants													
13 Public Heat Plants													
14 Autoproducer Heat Plants													
15 Heat pumps													
16 Electric boilers													
17 Gas Works													
18 Petroleum Refineries													
19 Coal Transformation													
20 Liquefaction Plants													
21 Other Transformation													
22 Own Use													
23 Distribution Losses													
24 TFC: Total Final Consumption													
25 Total Industry Sector													
26 Iron and Steel													
27 Chemical and Petrochemical													
28 Memo: Feedstock Use In Petchem. Industry													
29 Non-Ferrous Metals													
30 Non-Metallic Minerals													
31 Transport Equipment													
32 Machinery													
33 Mining and Quarrying													
34 Food and Tobacco													
35 Paper, Pulp and Printing													
36 Wood and Wood Products													
37 Construction													
38 Textile and Leather													
39 Non-specified Industry													
40 Total Transport Sector													
41 International Civil Aviation													
42 Domestic Air Transport													
43 Road													
44 Rail													
45 Pipeline Transport													
46 Internal Navigation													
47 Non-specified Transport													
48 Total Other Sectors													
49 Agriculture													
50 Commercial and Public Services													
51 Residential													
52 Non-specified Other													
53 Non-Energy Use													
54 Non-Energy Use Ind/Transf/Energy													
55 Non-Energy Use in Transport													
56 Non-Energy Use in Other Sectors													

Countries of GINFORS

NO	Country Code and Country	NO	Country Code and Country	NO	Country Code and Country
1	at Austria	26	us United States	51	si Slovenia
2	be Belgium	27	jp Japan	52	ua Ukraine
3	lu Luxembourg	28	kr Korea	53	pe Peru
4	dk Denmark	29	au Australia	54	cl Chile
5	fi Finland	30	nz New Zealand		
6	fr France	31	cn China		
7	de Germany	32	hk Hong Kong		
8	gr Greece	33	id Indonesia		
9	ie Ireland	34	in India		
10	it Italy	35	my Malaysia		
11	nl Netherlands	36	ph Philippines		
12	pt Portugal	37	sg Singapore		
13	es Spain	38	th Thailand		
14	se Sweden	39	tw Taiwan		
15	gb United Kingdom	40	ar Argentina		
16	cz Czech Republic	41	br Brasil		
17	hu Hungary	42	op OPEC		
18	pl Poland	43	bg Bulgaria		
19	sk Slovak Republic	44	cy Cyprus		
20	tr Turkey	45	ee Estonia		
21	ic Iceland	46	lv Latvia		
22	no Norway	47	lt Lithuania		
23	ch Switzerland	48	mt Malta		
24	ca Canada	49	ro Romania		
25	mx Mexico	50	ru Russia		

Sectors of GINFORS

OECD IO Industry	Nomenclature	ISIC Rev 3 Class	Original Country Table Class - USES NACE
1	AGRICULTURE, HUNTING, FORESTRY AND FISHING	01-05	01-05
2	MINING AND QUARRYING	10-14	10-14
3	FOOD PRODUCTS, BEVERAGES AND TOBACCO	15-16	15-16
4	TEXTILES, TEXTILE PRODUCTS, LEATHER AND FOOTWEAR	17-19	17-19
5	WOOD AND PRODUCTS OF WOOD AND CORK	20	20
6	PULP, PAPER, PAPER PRODUCTS, PRINTING AND PUBLISHING	21-22	21-22
7	COKE, REFINED PETROLEUM PRODUCTS AND NUCLEAR FUEL	23	23
8	CHEMICALS EXCLUDING PHARMACEUTICALS	24ex2423	24
9	PHARMACEUTICALS	2423	24,4
10	RUBBER AND PLASTICS PRODUCTS	25	25
11	OTHER NON-METALLIC MINERAL PRODUCTS	26	26
12	IRON & STEEL	271 2731	271,272 part 273
13	NON-FERROUS METALS	272 2732	274, part 273
14	FABRICATED METAL PRODUCTS, except machinery and equipment	28	28
15	MACHINERY AND EQUIPMENT, N.E.C.	29	29
16	OFFICE, ACCOUNTING AND COMPUTING MACHINERY	30	30
17	ELECTRICAL MACHINERY AND APPARATUS, NEC	31	31
18	RADIO, TELEVISION AND COMMUNICATION EQUIPMENT	32	32
19	MEDICAL, PRECISION AND OPTICAL INSTRUMENTS	33	33
20	MOTOR VEHICLES, TRAILERS AND SEMI-TRAILERS	34	34
21	BUILDING AND REPAIRING OF SHIPS AND BOATS	351	351
22	AIRCRAFT AND SPACECRAFT	353	353
23	RAILROAD EQUIPMENT AND TRANSPORT EQUIPMENT N.E.C.	352, 359	352,354
24	MANUFACTURING NEC; RECYCLING	36-37	36-37
25	ELECTRICITY, GAS AND WATER SUPPLY	40-41	40-41
26	CONSTRUCTION	45	45
27	WHOLESALE AND RETAIL TRADE; REPAIRS	50-52	50-52
28	HOTELS AND RESTAURANTS	55	55
29	TRANSPORT AND STORAGE	60-63	60-63
30	POST AND TELECOMMUNICATIONS	64	64
31	FINANCE, INSURANCE	65-67	65-67
32	REAL ESTATE ACTIVITIES	70	70
33	RENTING OF MACHINERY AND EQUIPMENT	71	71
34	COMPUTER AND RELATED ACTIVITIES	72	72
35	RESEARCH AND DEVELOPMENT	73	73
36	OTHER BUSINESS ACTIVITIES	74	74
37	PUBLIC ADMIN. AND DEFENCE; COMPULSORY SOCIAL SECURITY	75	75
38	EDUCATION	80	80
39	HEALTH AND SOCIAL WORK	85	85
40	OTHER COMMUNITY, SOCIAL AND PERSONAL SERVICES	90-93	90-93
41	PRIVATE HOUSEHOLDS WITH EMPLOYED PERSONS and EXTRA TERRITORIAL ORGANISATION	95-99	95-99
42	SBFD + adj		N/A